

OPERATING INSTRUCTIONS
READ BEFORE OPERATING

!!!! DANGER !!!!

Exercise EXTREME CAUTION when plowing and always at a slow speed.

!!!! WARNING !!!!

TO AVOID SERIOUS INJURY OR DEATH:

1. DO NOT EXCEED 5 MPH WITH BLADE INSTALLED.
2. OPERATE WITH EXTREME CAUTION ON SLOPES, STEEP GRADES AND ROUGH TERRAIN.
3. KEEP AWAY FROM BLADE AND MOVING PARTS DURING OPERATION.
4. WHEN PLOWING DIRT OR SNOW INTO A PILE START BACKING UP BEFORE RAISING BLADE.
5. DO NOT RAM THE BLADE INTO THE PILE. ** SLOW DOWN BEFORE HITTING PILE. **
6. BE AWARE OF POSSIBLE HIDDEN OBJECTS UNDER SNOW.

!!! CAUTION !!!

TO AVOID PERSONAL OR OTHER INJURY:

1. READ BLADE OWNER'S MANUAL, ZTR MOWER OPERATOR'S MANUAL, AND SAFETY DECALS BEFORE OPERATING.
2. WEAR HEAD PROTECTION, SAFETY GLASSES, AND SHOES AS RECOMMENDED IN ZTR MOWER OPERATOR'S MANUAL.
3. ALLOW NO RIDERS ON BLADE OR ZTR MOWER WHILE MOVING OR STATIONARY.
4. KEEP BYSTANDERS AWAY FROM BLADE OR ZTR MOWER WHILE MOVING OR STATIONARY.
5. BEFORE ADJUSTING BLADE ANGLE, STOP ZTR ENGINE, SET AND LOCK BRAKES, RAISE BLADE. DO NOT ATTEMPT TO RAISE BLADE BY HAND.
6. BEFORE ADJUSTING BLADE HEIGHT: LOWER BLADE TO THE DOWN POSITION.
7. WHEN BLADE IS NOT IN USE, STOP ENGINE, SET AND LOCK BRAKES, AND LOWER BLADE TO DOWN POSITION.

!!!! OPERATION !!!!

*** Your blade and hardware were designed with your safety in mind. In order to protect you and your ZTR mower, certain parts of the blade and/ or hardware are designed to fail when the equipment is over stressed. For this reason Push Tubes, Blade Hinges, Tube Frame Attaching Brackets, Push Plate Attaching pins and Clevis Pins are not covered by warranty.

* Blade angle is adjustable. Move blade to the up position. To move the blade left, right or straight, pull the Blade Position Lever ahead and turn the blade to the desired position. The Lever will spring back when the blade is at the correct angle.

* The blade is raised or lowered using the control switch. The blade skids are adjustable so the blade can be lowered but still held a certain distance off the ground.

* The blade is designed to trip when it strikes an object or digs in too far. When pressure is released the blade springs into position. Blade spring tension may be set stiffer by tightening the Locknuts on the bottom of the Eyebolts. For less spring tension, loosen the Locknuts.

*Do not exceed 5 MPH with blade installed.

*Operate with extreme caution on slopes, steep grades and rough terrain.

*Keep away from blade and moving parts during operation.

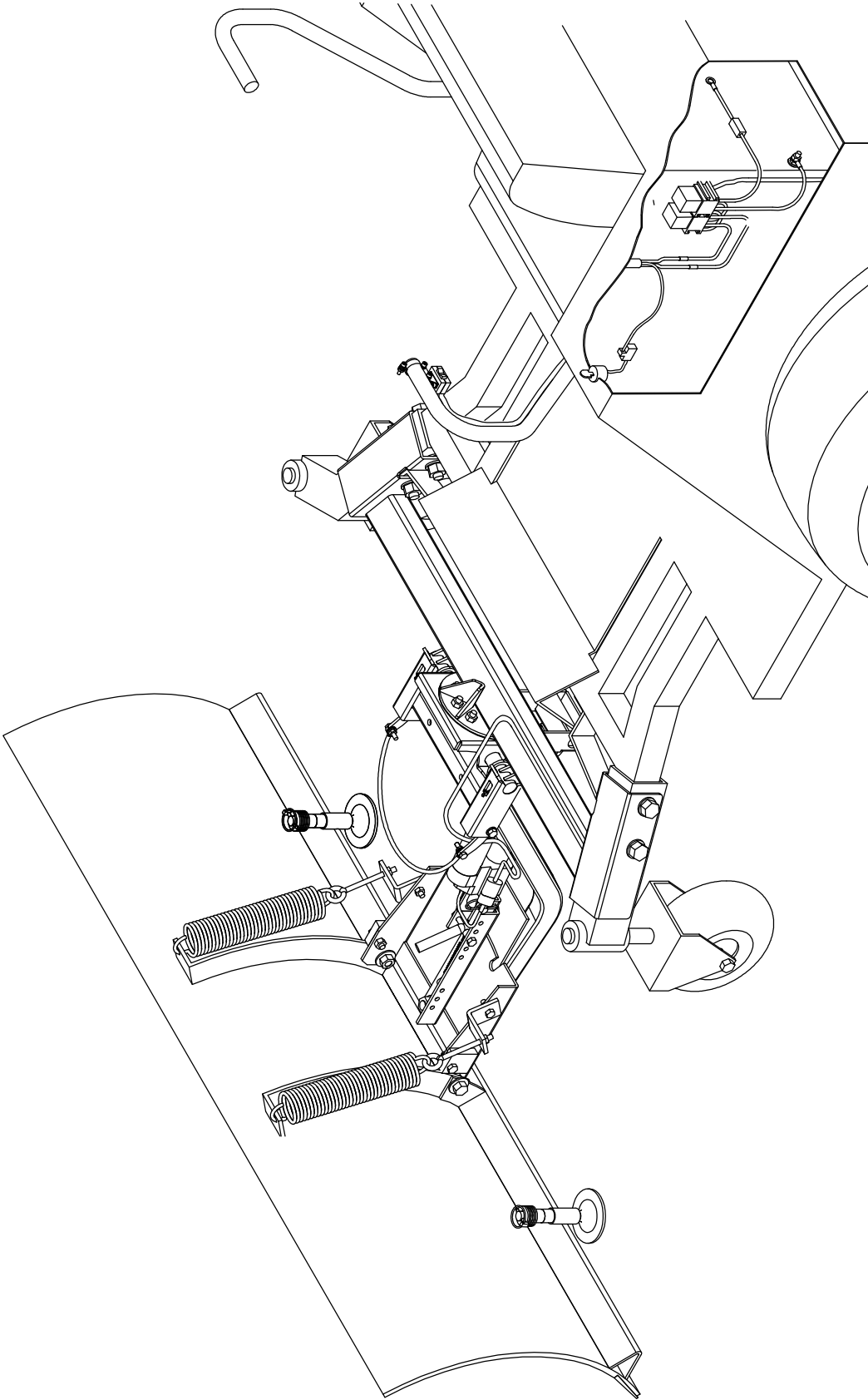

PLOW ASSEMBLY	PAGE 2
HNGE AND BLADE POSITION LEVER ASSEMBLY	PAGE 4
PUSH TUBE ASSEMBLT	PAGE 6
PLOW/HINGE PUSH TUBE ASSEMBLY	PAGE 8
SCAG SWIVEL MOUNT ASSEMBLY	PAGE 10
SCAG SWIVEL MOUNT ASSEMBLY INSTALLATION	PAGE 12
ACTUATOR INSTALLATION	PAGE 14
ELECTRICAL COMPONENT INSTALLATION	PAGE 15

PLOW ASSEMBLY

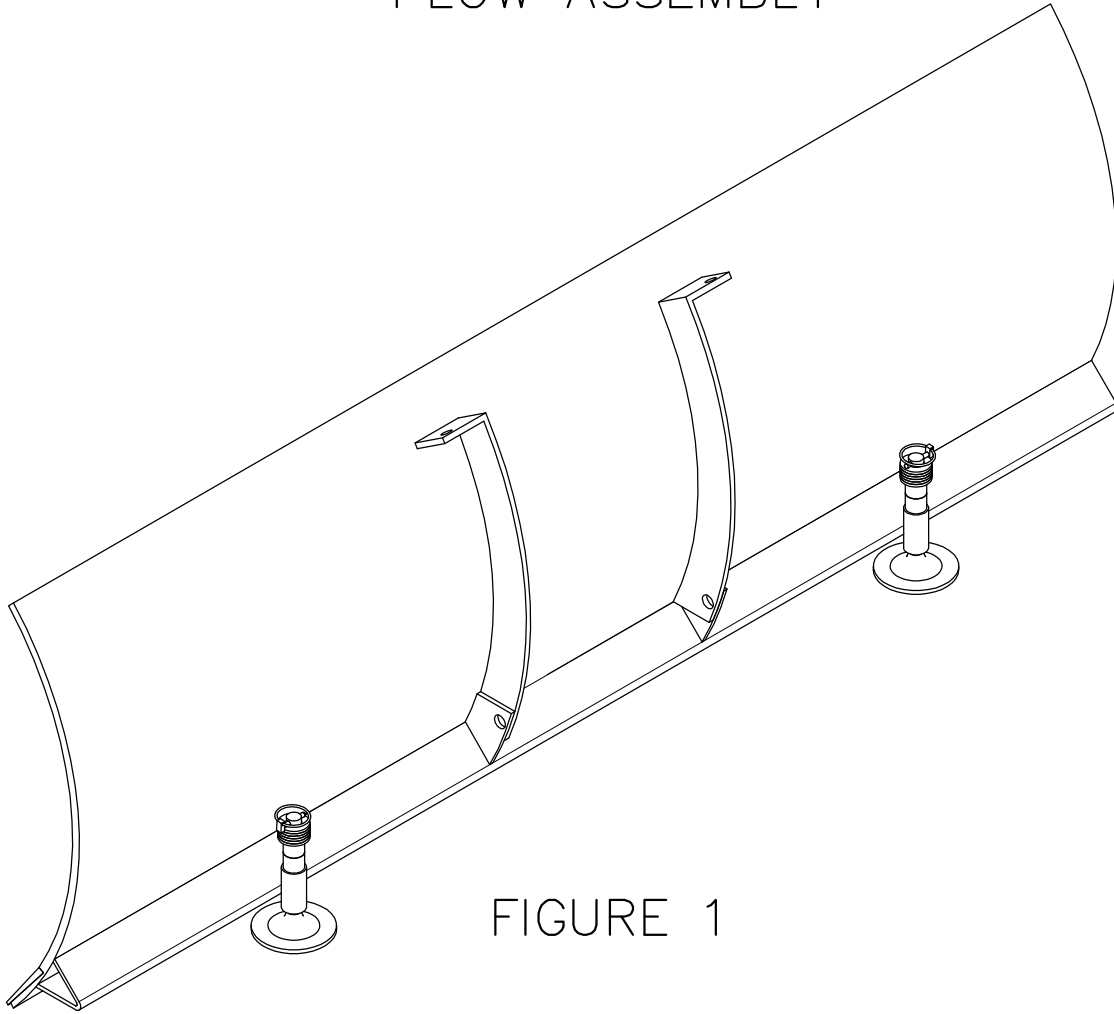

FIGURE 1

PLOW ASSEMBLY PER FIGURE 1 AND FIGURE 2
PARTS REQUIRED PER THE BILL OF MATERIALS BELOW

ITEM NO.	QTY.	PART NO.	DESCRIPTION
1	1	CYC3111	48" PLOW
2	1	CYC0004	DOUBLE SIDED WEAR BAR
3	2	PUR1467	SKID
4	4	PUR0400	SKID SPACER
5	12	-	FLAT WASHER 5/8" SAE
6	2	PUR1359	QUICK PIN 3/16" x 1.5"
7	7	-	CARRIAGE BOLT 5/16" x 1"
8	7	-	NYLOCK NUT 5/16"

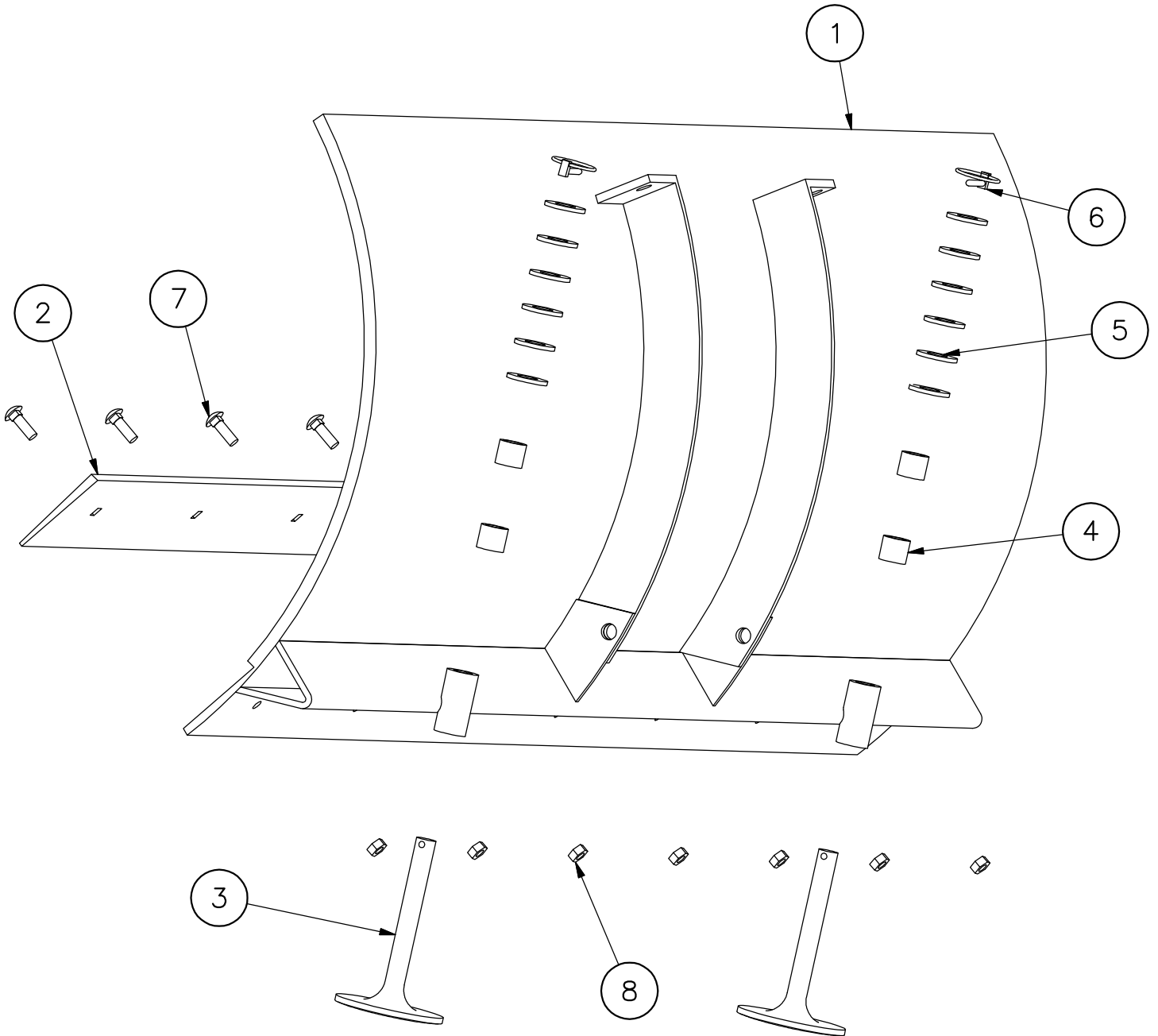

FIGURE 2

HINGE AND BLADE POSITION LEVER ASSEMBLY

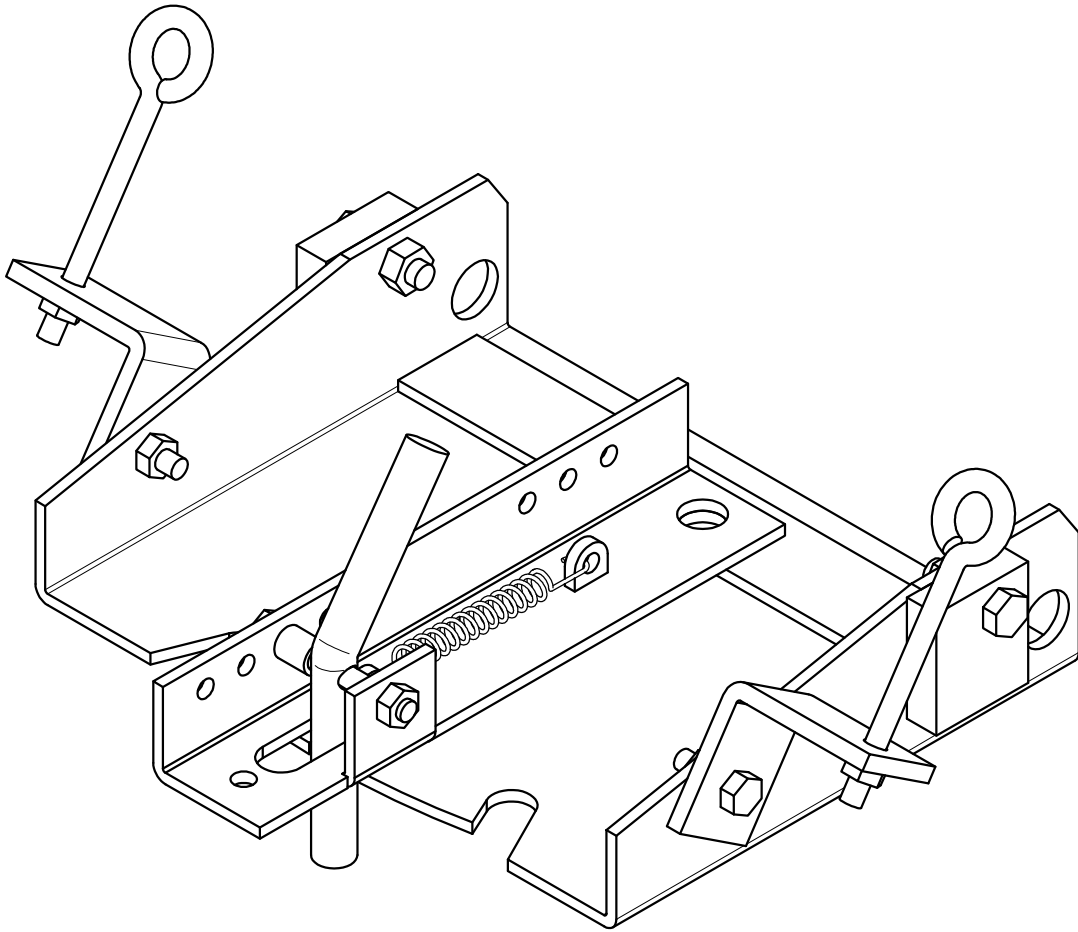
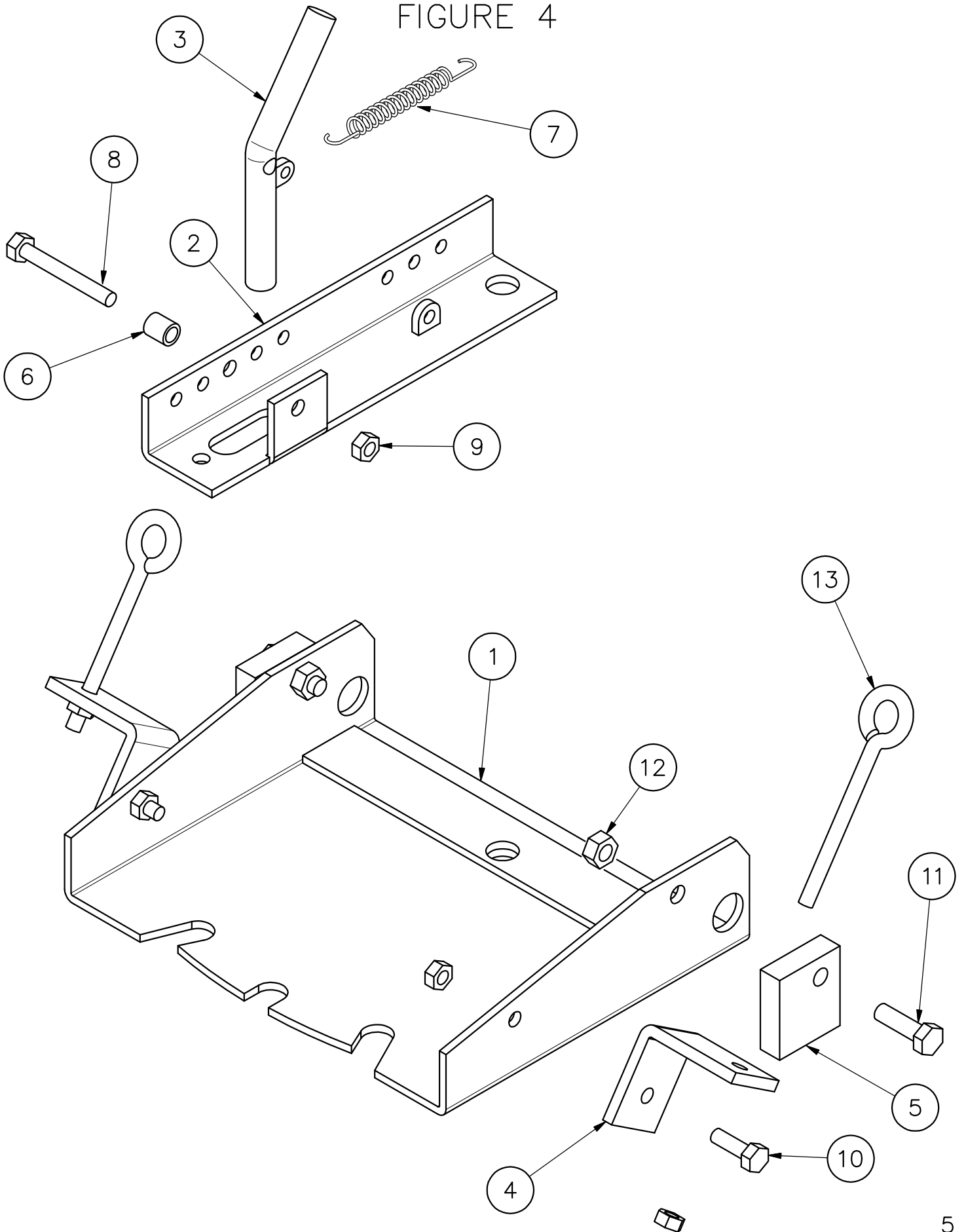

FIGURE 3

HINGE AND BLADE POSITION LEVER ASSEMBLY PER FIGURE 3 AND FIGURE 4
PARTS REQUIRED PER THE BILL OF MATERIALS BELOW

ITEM NO.	QTY.	PART NO.	DESCRIPTION
1	1	CYC2389	HINGE
2	1	CYC0345	BLADE POSITION LEVER BRACKET
3	2	CYC2259	BLADE POSITION LEVER
4	2	CYC0812	BLADE SPRING BRACKET
5	2	CYC0813	BLADE STOP
6	2	PUR1361	BUSHING
7	1	PUR1437	BLADE LEVER SPRING
8		-	BOLT 5/16" x 2.25"
9	5	-	NYLOCK NUT 5/16"
10	2	-	BOLT 5/16" x 1.00"
11	2	-	BOLT 3/8" x 1.25"
12	2	-	NYLOCK NUT 3/8"
13	2	-	EYE BOLT 5/16" x 4.25

FIGURE 4



PUSH TUBE ASSEMBLY

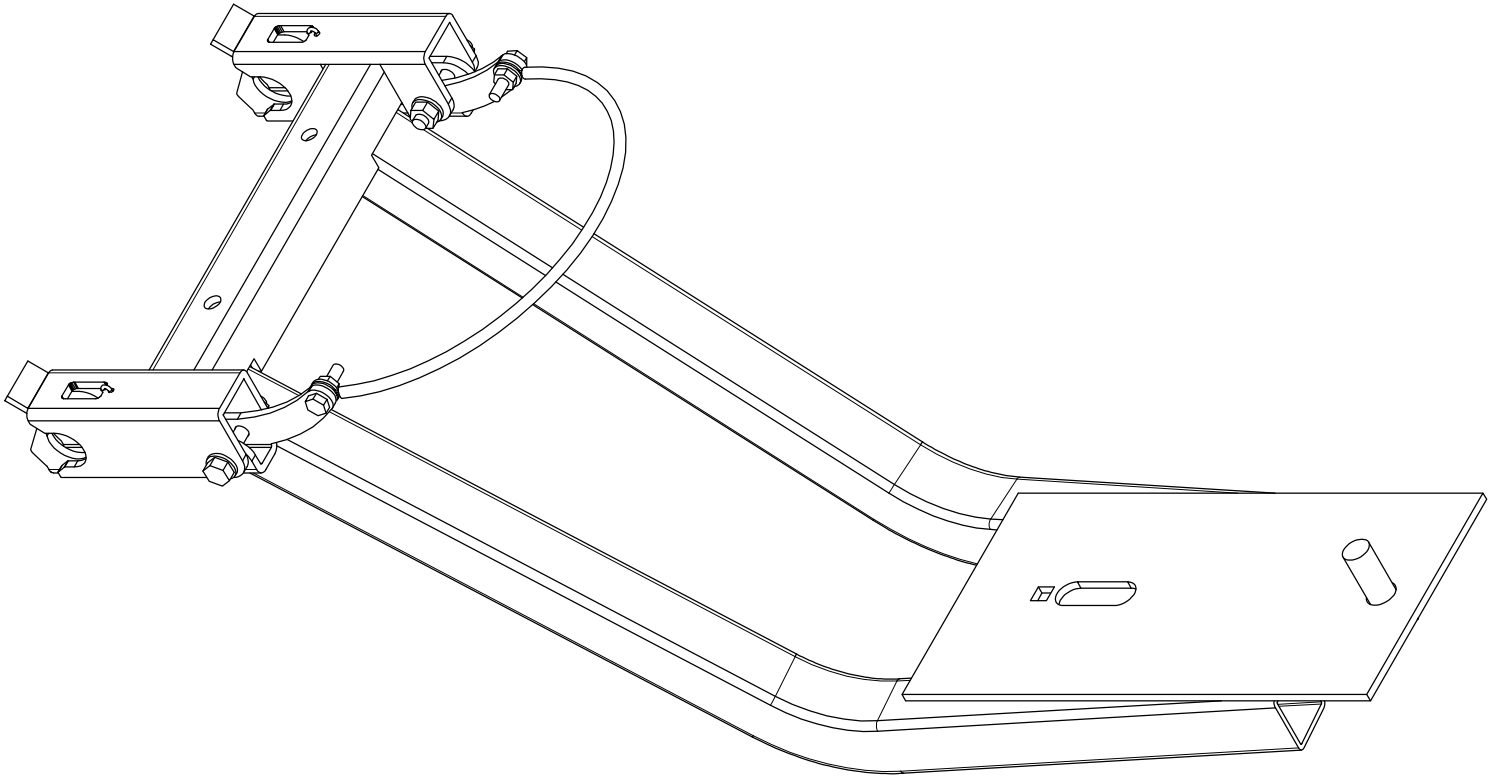
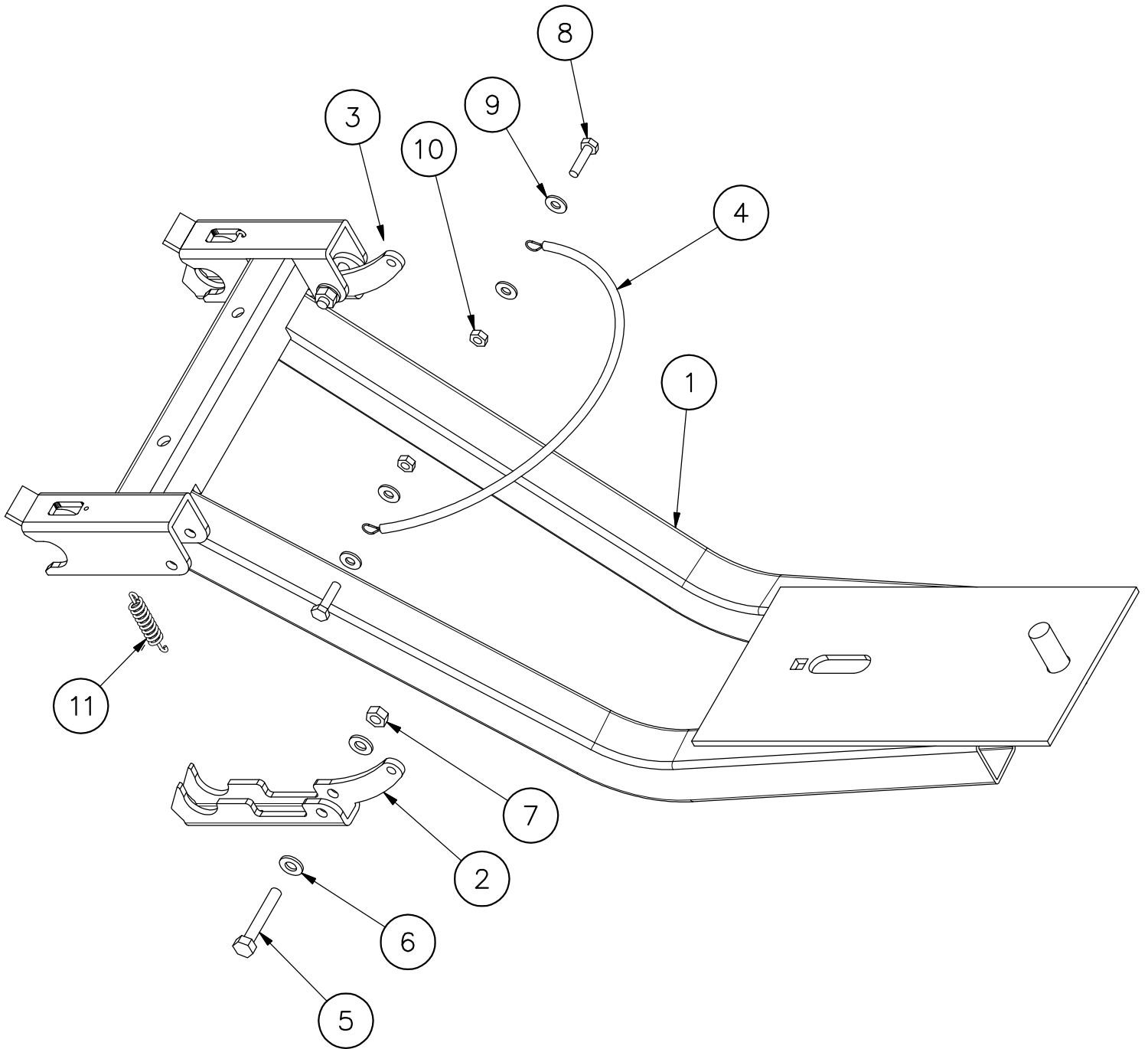

FIGURE 5

PUSH TUBE ASSEMBLY PER FIGURE 5 AND FIGURE 6
PARTS REQUIRED PER THE BILL OF MATERIALS BELOW

ITEM NO.	QTY.	PART NO.	DESCRIPTION
1	1	ZTRW0001	PUSH TUBE
2	1	ZTRP0001	RIGHT LOWER QUICK CONNECT
3	1	ZTRP0001A	LEFT LOWER QUICK CONNECT
4	1	ZTRP0024	QUICK RELEASE CABLE
5	2	-	BOLT 5/16" x 2.00"
6	4	-	FLAT WASHER 5/16" SAE
7	2	-	NYLOCK NUT 5/16"
8	2	-	BOLT 1/4" x 1.00"
9	4	-	FLAT WASHER 1/4" SAE
10	2	-	NYLOCK NUT 1/4"
11	2	ZTRPUR001	QUICK RELEASE SPRING

FIGURE 6



PLOW / HINGE / PUSH TUBE ASSEMBLY

FIGURE 7

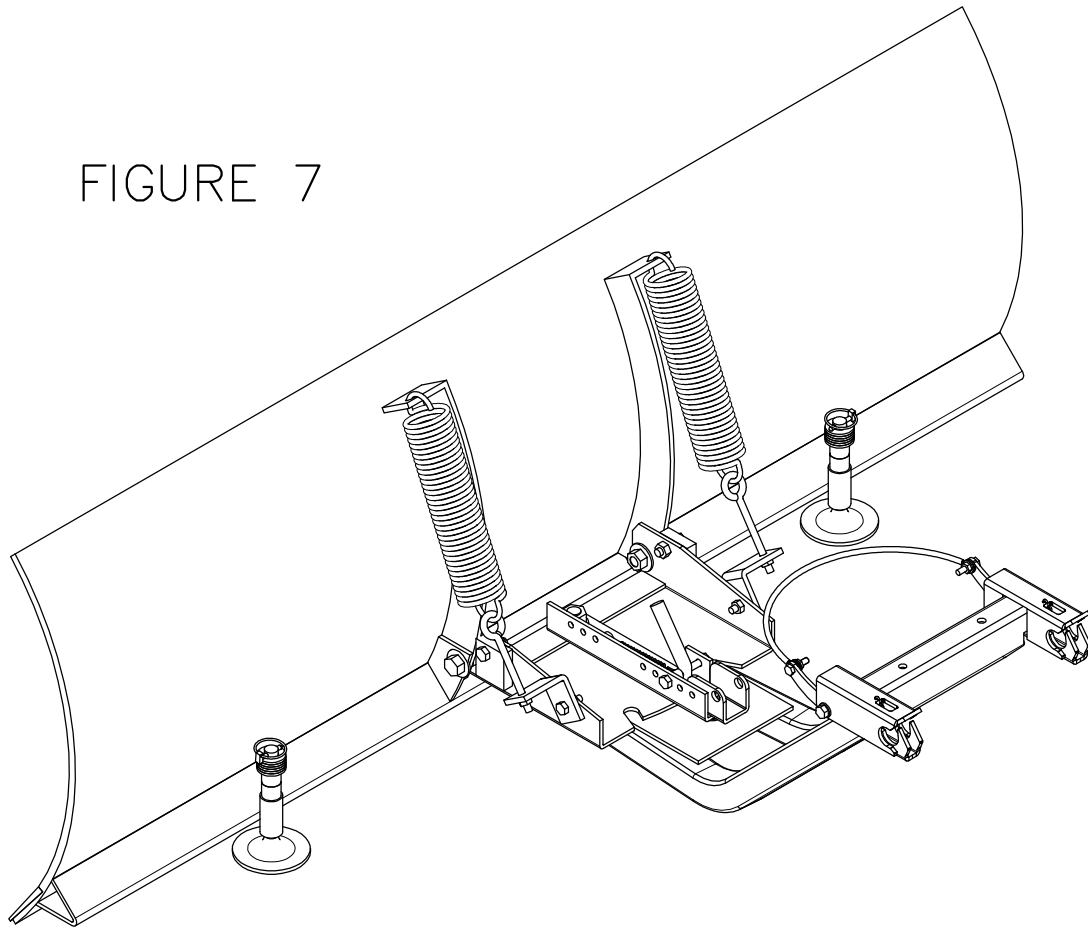

PLOW / HINGE / PUSH TUBE ASSEMBLY PER FIGURE 7 AND FIGURE 8
PARTS REQUIRED PER THE BILL OF MATERIALS BELOW

ITEM NO.	QTY.	PART NO.	DESCRIPTION
1	1	-	PLOW ASSEMBLY
2	1	-	HINGE AND BLADE LEVER ASSEMBLY
3	1	-	PUSH TUBE ASSEMBLY
4	1	ZTRP0005	LOWER ACTUATOR BRACKET
5	1	-	CARRAGE BOLT 3/8" x 1.50"
6	1	-	FLAT WASHER 3/8" SAE
7	1	-	NYLOCK NUT 3/8"
8	2	PUR1409	BLADE SPRING
9	2	-	BOLT 1/2" x 1.5"
10	4	-	FLAT WASHER 1/2" SAE
11	2	-	BUSHING 7/8" O.D. STL.
12	2	-	NYLOCK NUT 1/2" YELLOW
13	3	-	FLAT WASHER 3/8" SAE
14	1	-	NYLOCK NUT 5/8"

FIGURE 8

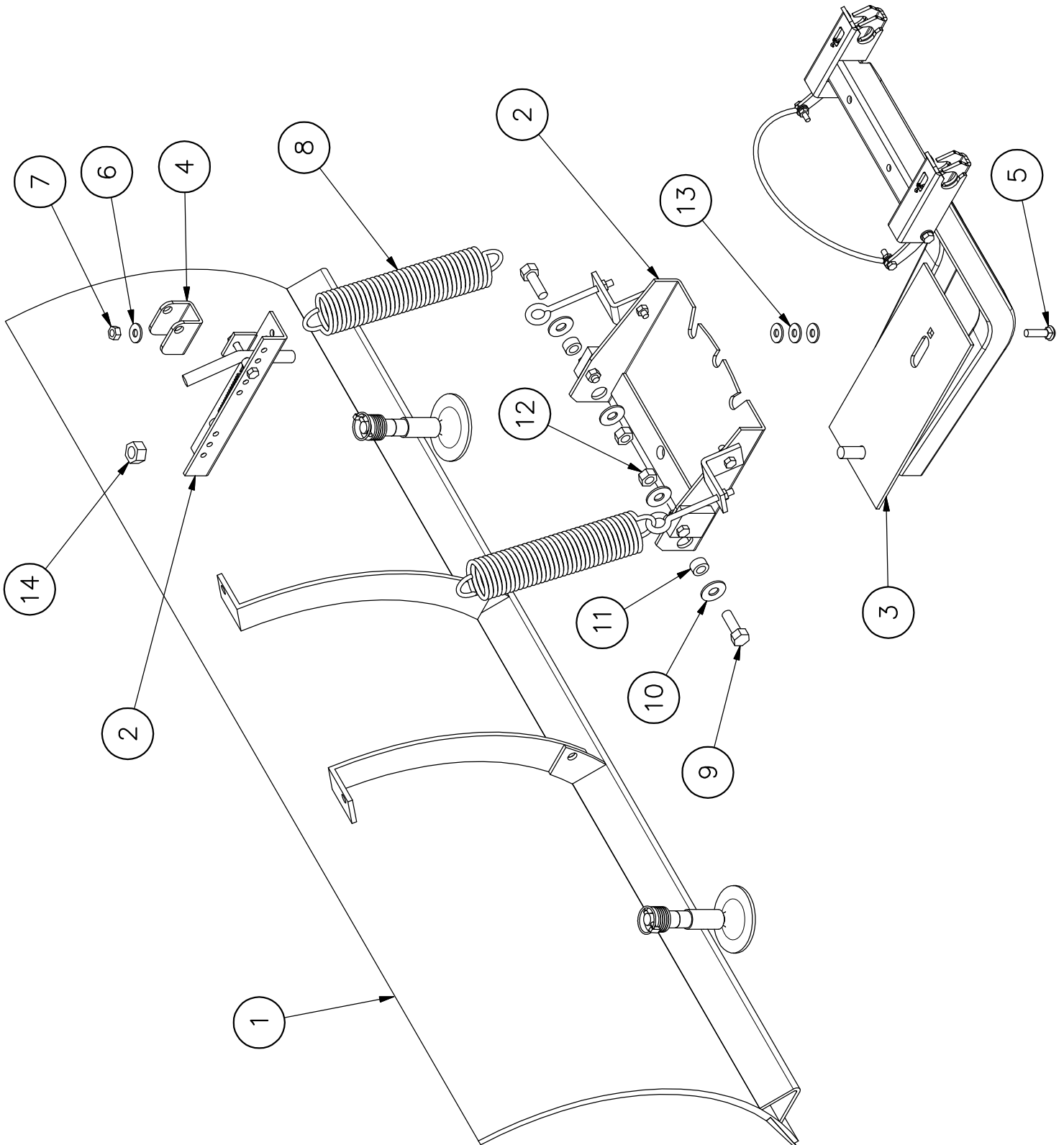

SCAG SWIVEL MOUNT ASSEMBLY

FIGURE 9

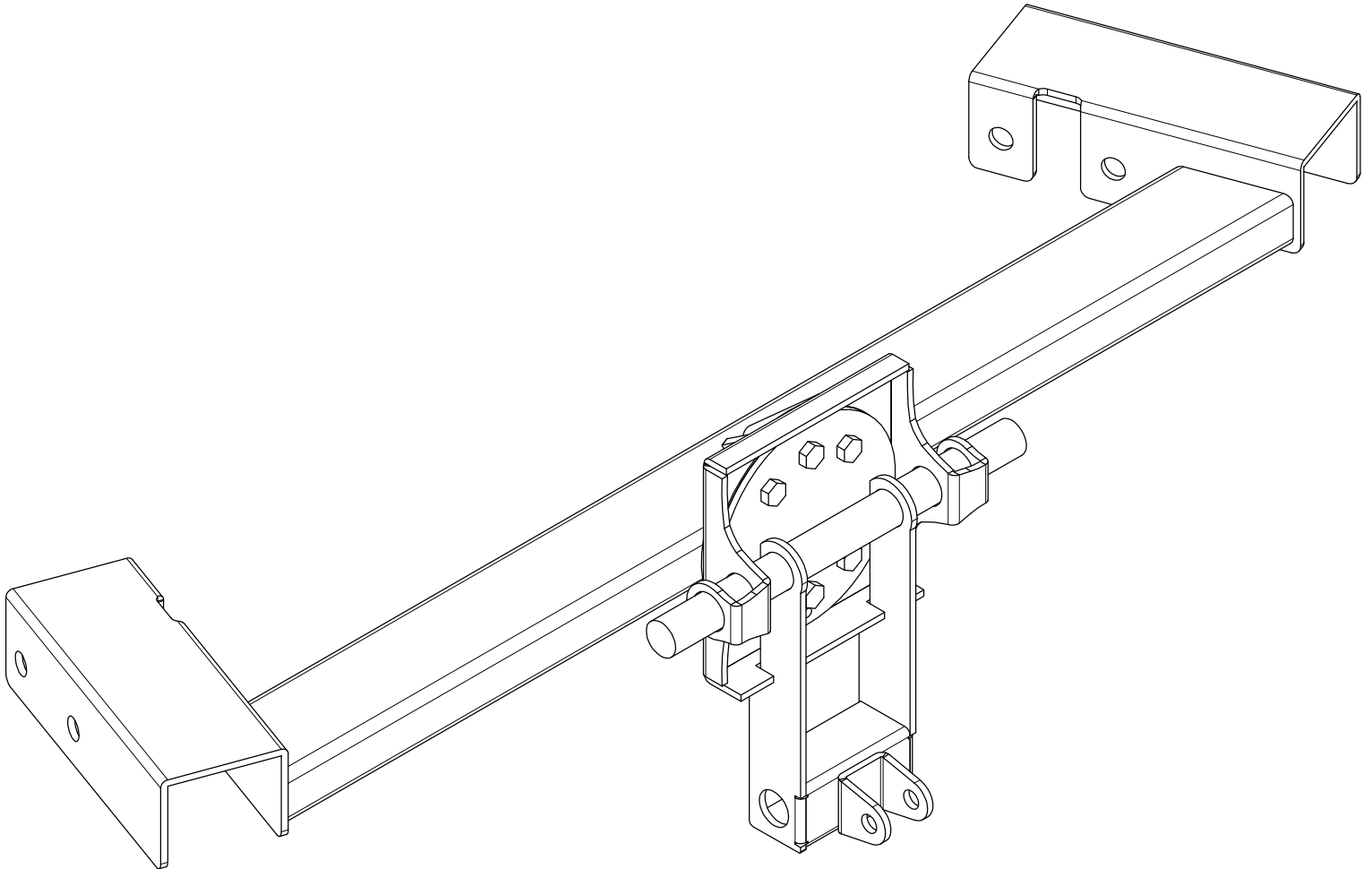

SCAG SWIVEL MOUNT ASSEMBLY PER FIGURE 9 AND FIGURE 10
PARTS REQUIRED PER THE BILL OF MATERIALS BELOW

ITEM NO.	QTY.	PART NO.	DESCRIPTION
1	1	ZTRW0002	SWIVEL MOUNT
2	1	ZTRW0009	SCAG MOUNT
3	1	ZTRP0016	6" FRONT HOLD PLATE
4	1	ZTRW0015	4" CENTER PIVOT DISC
5	2	ZTRP0022	TEFLON WASHER
6	6	-	BOLT 3/8" x 1.25"
7	6	-	NYLOCK NUT 3/8"

FIGURE 10

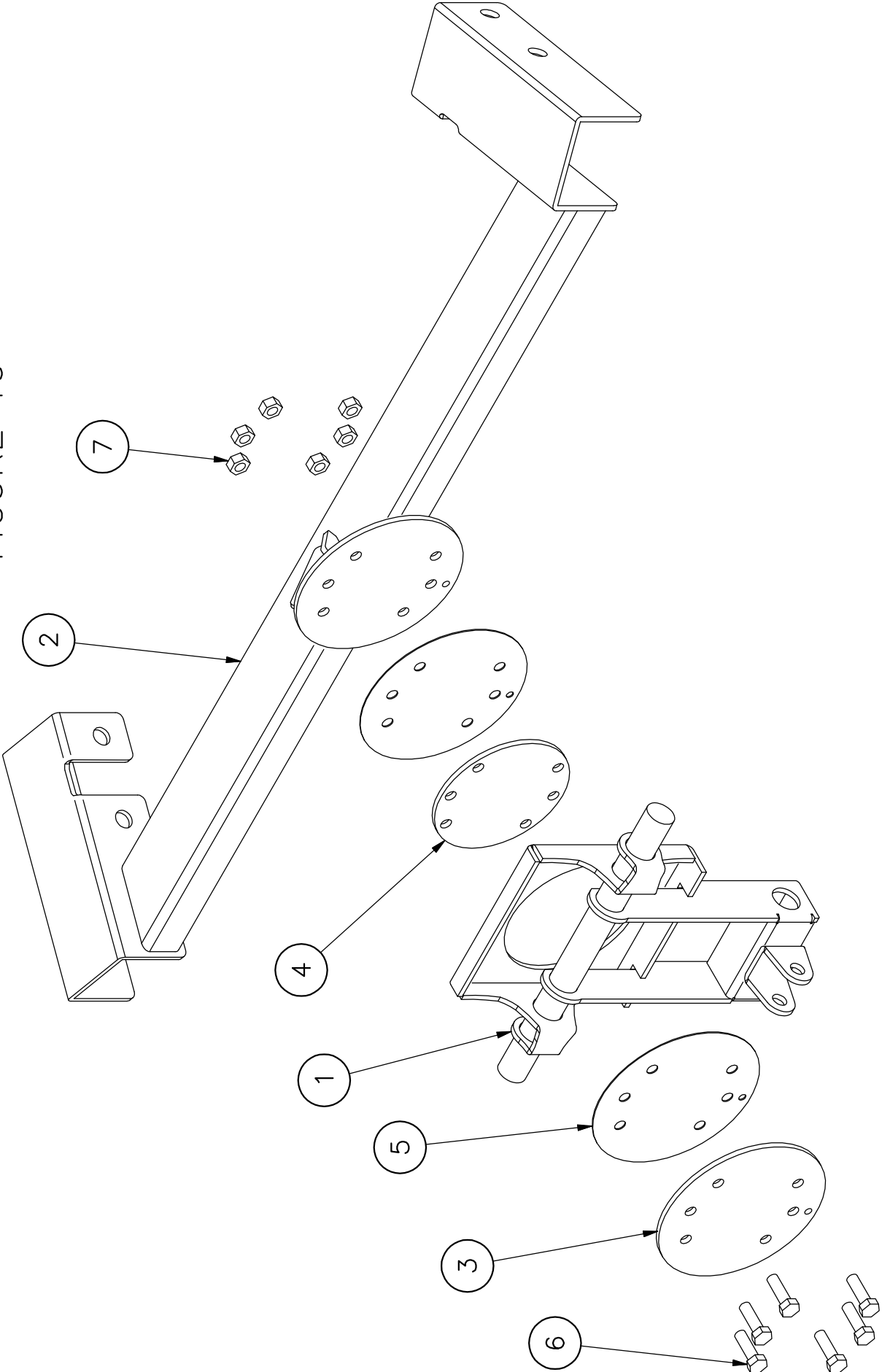

SCAG SWIVEL MOUNT ASSEMBLY INSTALLATION

FIGURE 11

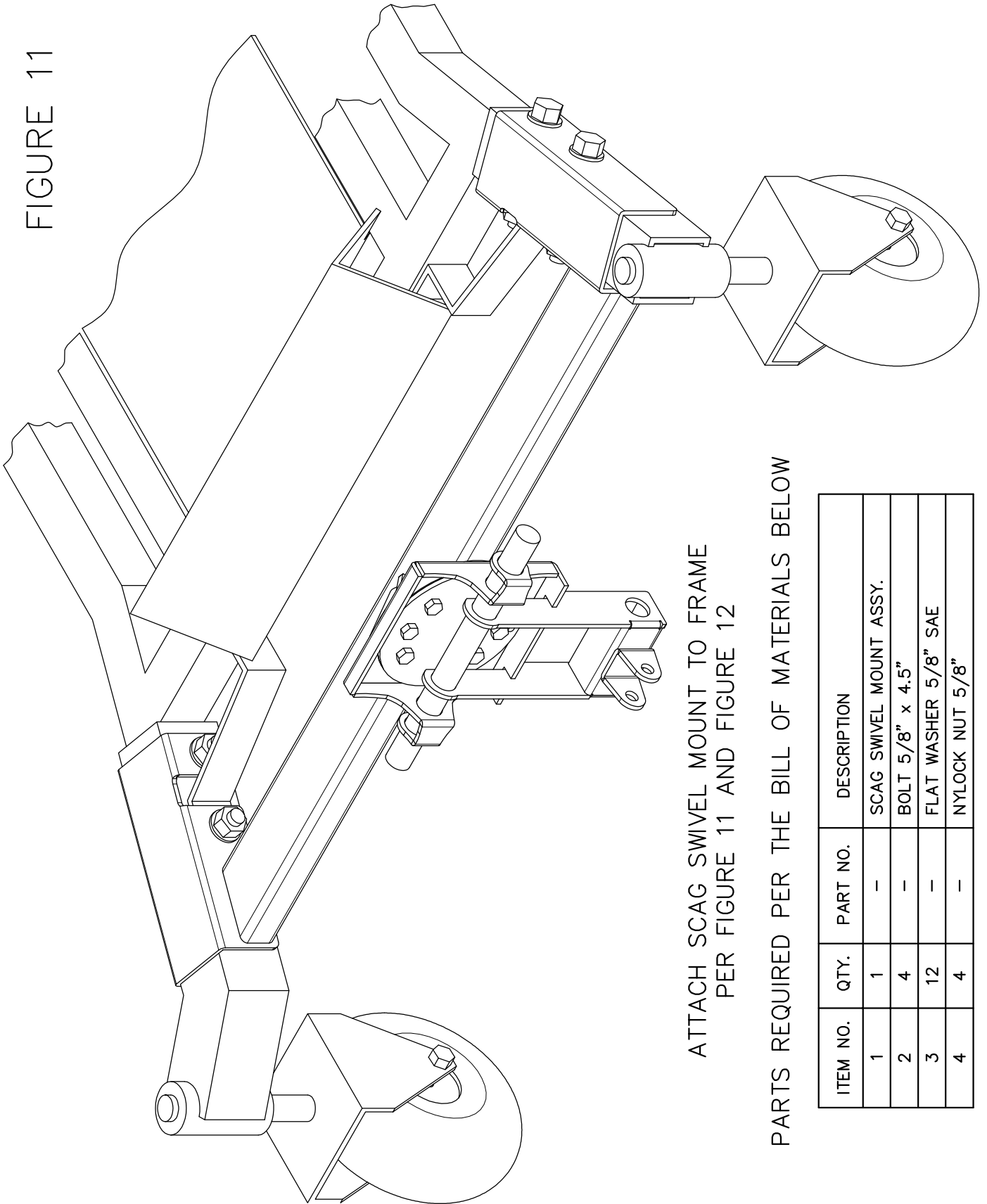

ATTACH SCAG SWIVEL MOUNT TO FRAME
PER FIGURE 11 AND FIGURE 12

PARTS REQUIRED PER THE BILL OF MATERIALS BELOW

ITEM NO.	QTY.	PART NO.	DESCRIPTION
1	1	-	SCAG SWIVEL MOUNT ASSY.
2	4	-	BOLT 5/8" x 4.5"
3	12	-	FLAT WASHER 5/8" SAE
4	4	-	NYLOCK NUT 5/8"

FIGURE 12

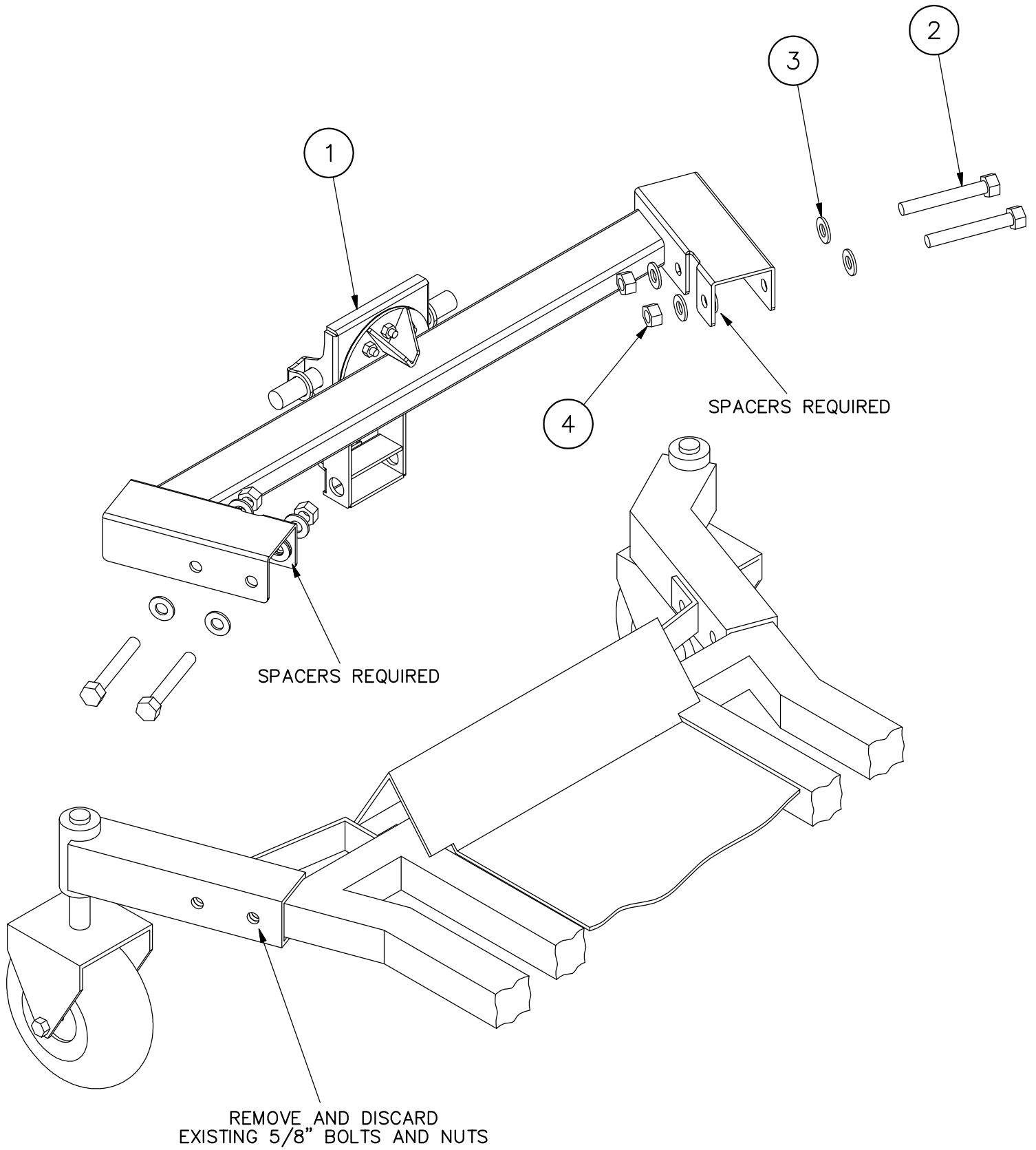

ACTUATOR INSTALLATION

ENGAGE PLOW/HINGE/TUBE ASSEMBLY WITH SWIVEL MOUNT

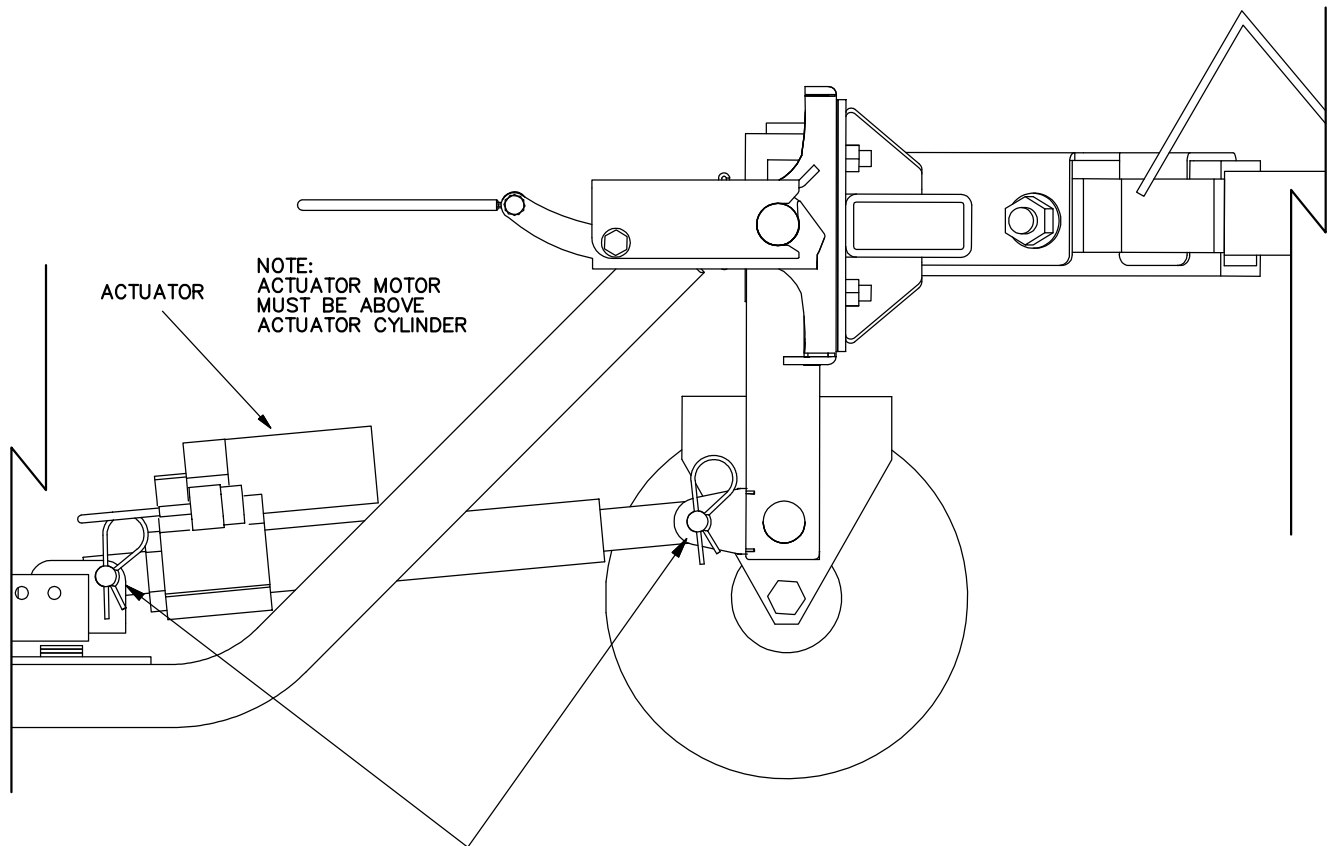
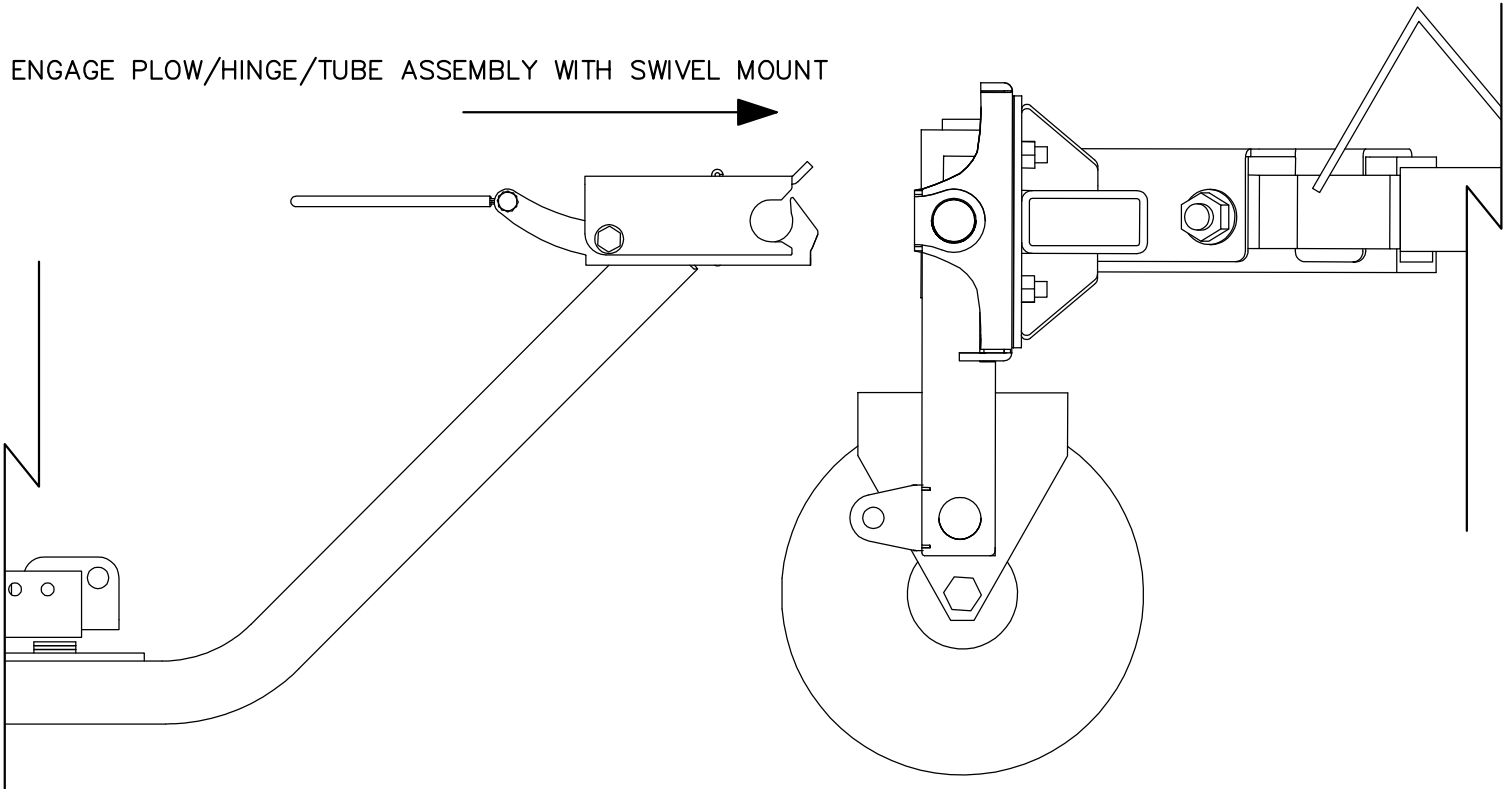

1/2" x 2.00" CLEVIS PIN WITH COTTER PIN (2)

ELECTRICAL COMPONENT INSTALLATION

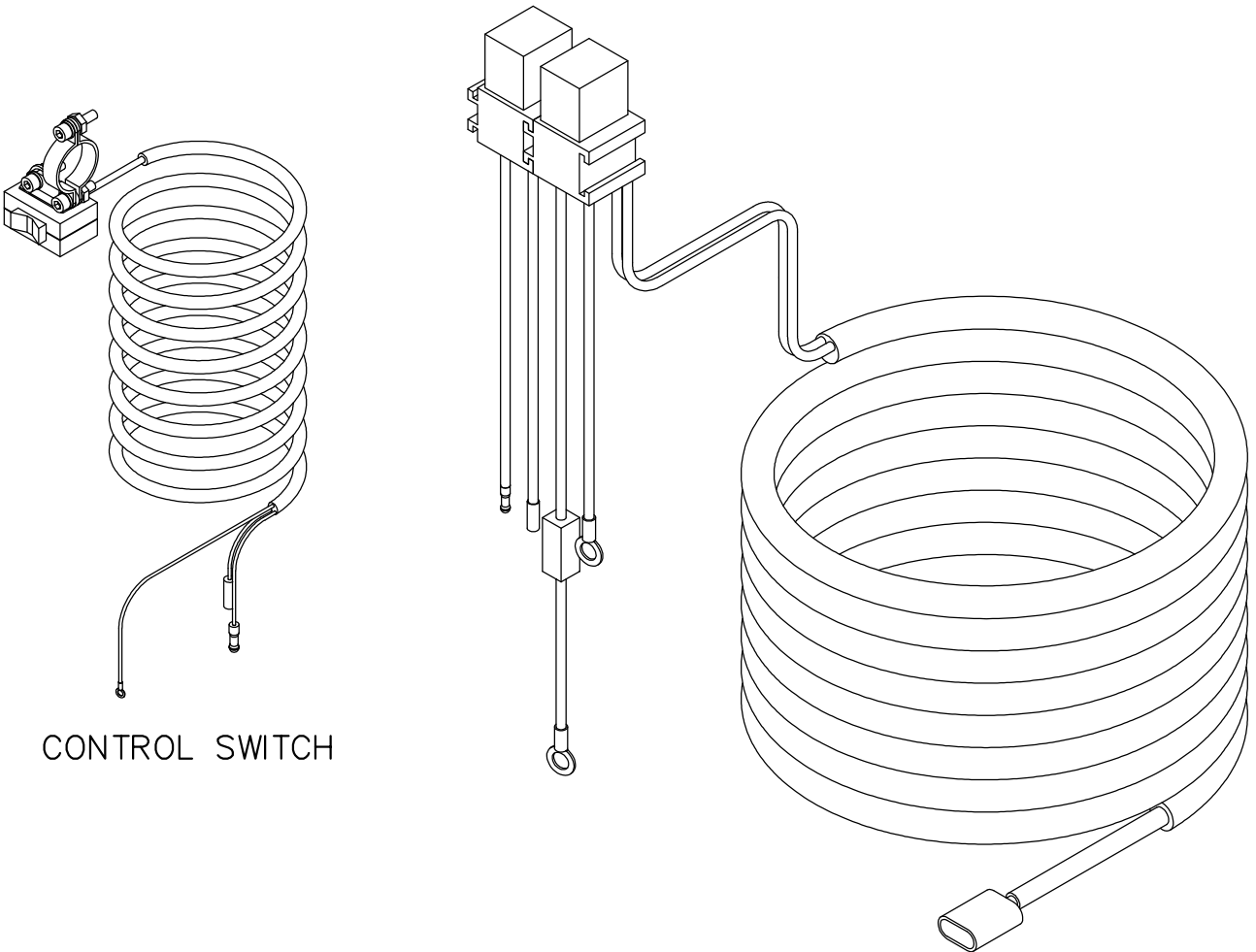

CONTROL SWITCH

RELAY/ACTUATOR WIRING HARNESS

CONTROL SWITCH BRACKET ASSEMBLY

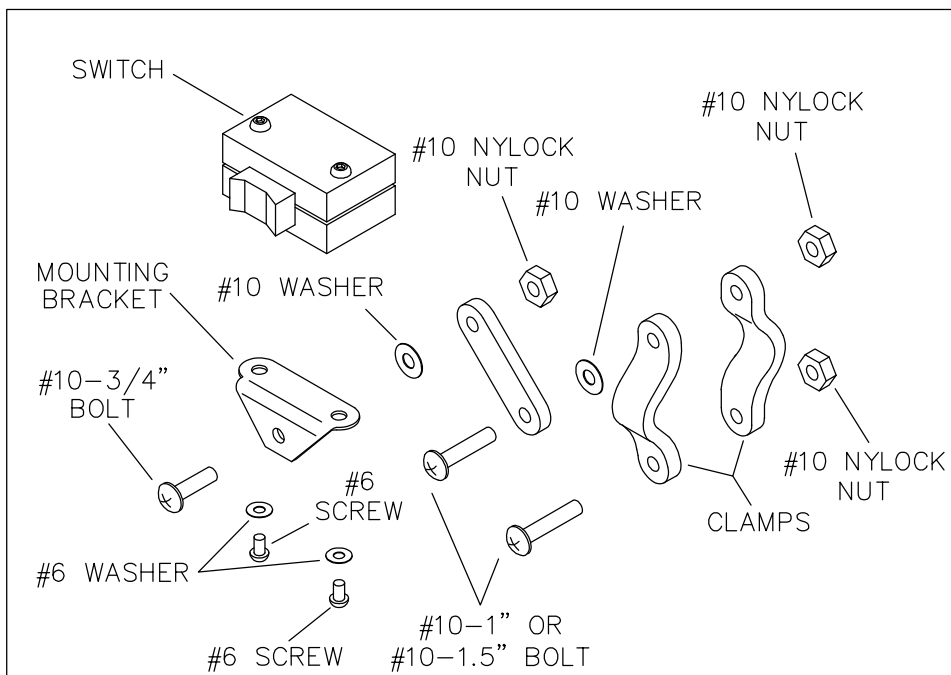

ELECTRICAL COMPONENT INSTALLATION PER FIGURE 13 AND FIGURE 14

NOTE:

1. SECURE RELAYS IN A DRY LOCATION
2. KEEP ALL WIRING CLEAR OF ROTATING OR MOVING PARTS
3. DO NOT ROUTE ANY WIRES NEAR EXHAUST COMPONENTS

FIGURE 13

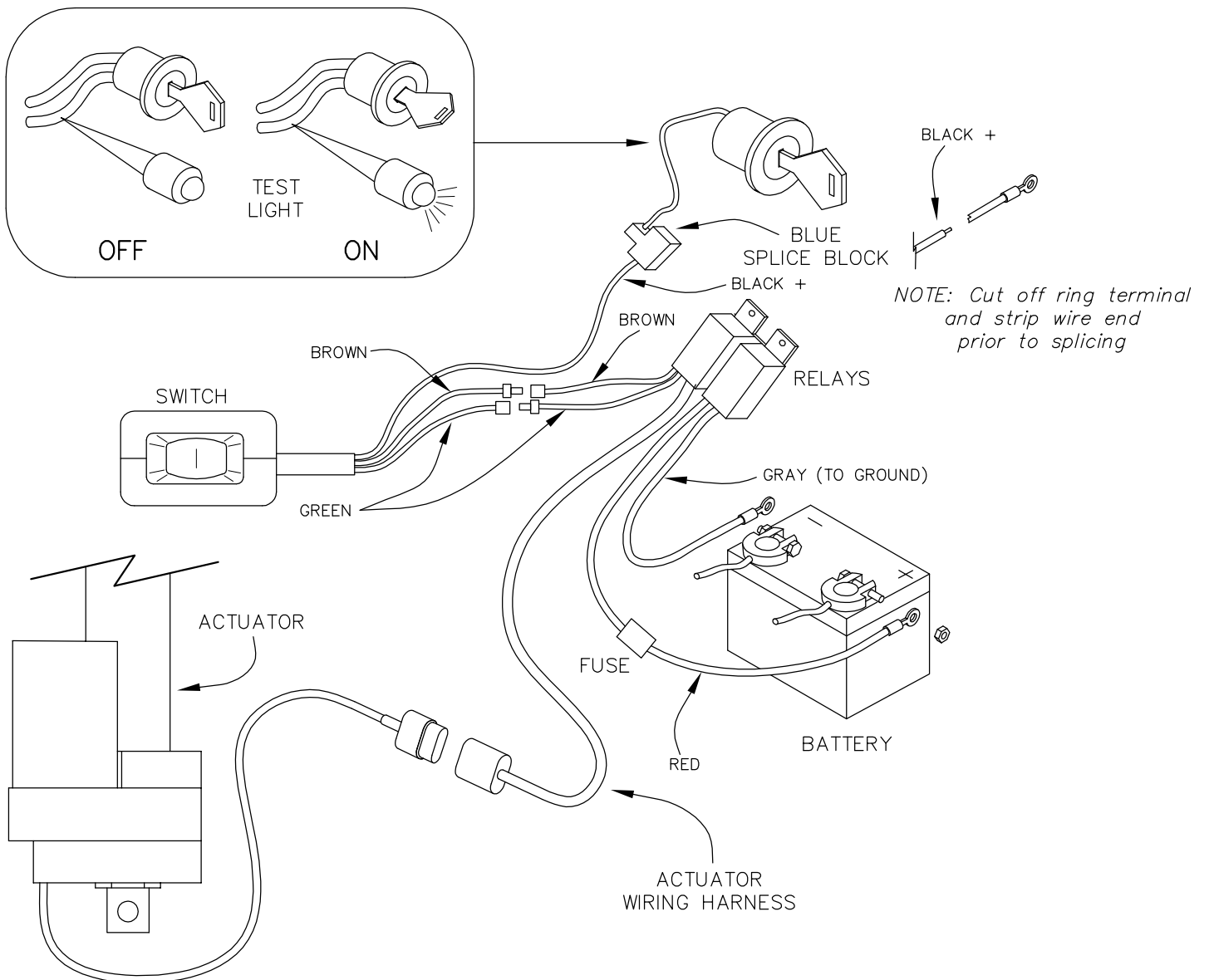

CLAMP SWITCH TO HANDLE
ROUTE SWITCH WIRING HARNESS
TO RELAYS AND ATTACH TO FRAME

ATTACH RELAYS TO FRAME
ROUTE ACTUATOR WIRING HARNESS
TO FRONT OF MACHINE AND ATTACH TO FRAME

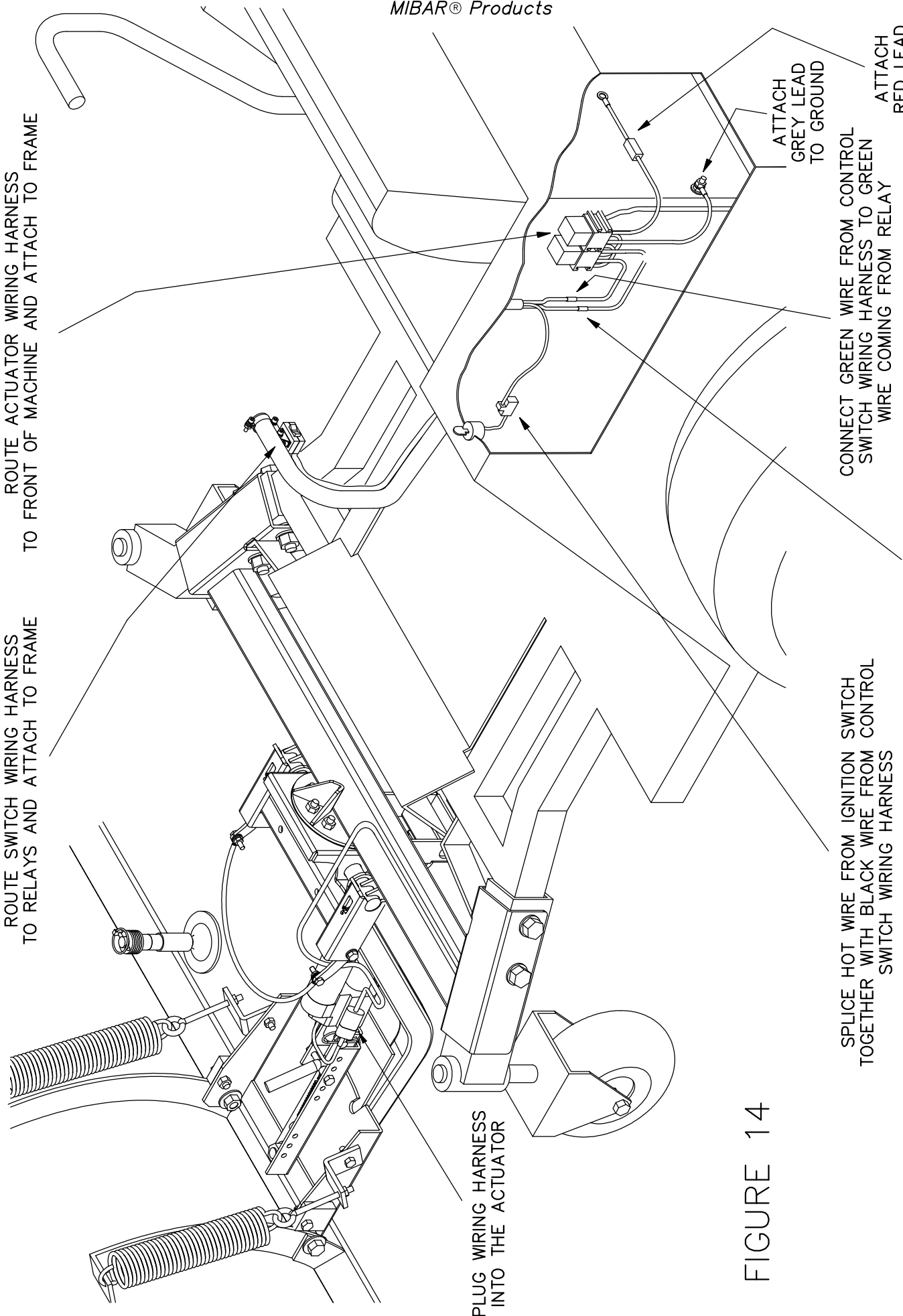

PLUG WIRING HARNESS
INTO THE ACTUATOR

SPLICE HOT WIRE FROM IGNITION SWITCH
TOGETHER WITH BLACK WIRE FROM CONTROL
SWITCH WIRING HARNESS

CONNECT GREEN WIRE FROM CONTROL
SWITCH WIRING HARNESS TO GREEN
WIRE COMING FROM RELAY

CONNECT BROWN WIRE FROM CONTROL
SWITCH WIRING HARNESS TO BROWN
WIRE COMING FROM RELAY

ATTACH
GREY LEAD
TO GROUND

ATTACH
RED LEAD
TO POSITIVE
BATTERY TERMINAL

FIGURE 14